

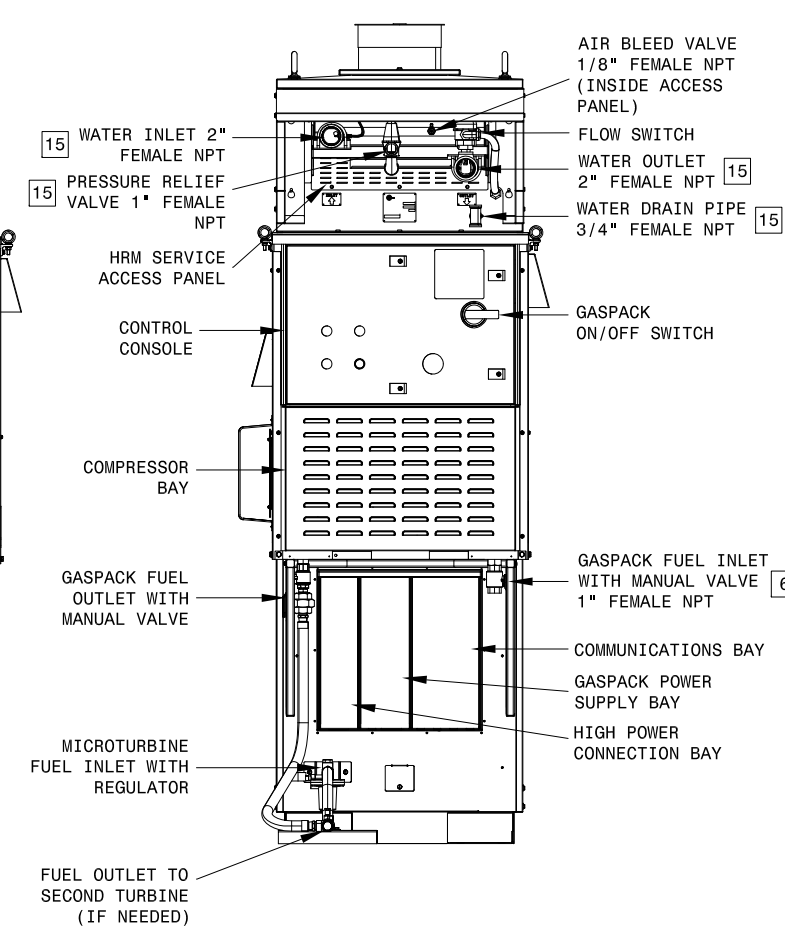

**NOTICE**

THIS DOCUMENT CONTAINS INFORMATION WHICH IS BOTH CONFIDENTIAL AND PROPRIETARY TO CAPSTONE TURBINE CORPORATION. NEITHER THIS DOCUMENT NOR THE INFORMATION CONTAINED HEREIN SHALL BE COPIED, DISCLOSED TO OTHERS OR USED FOR ANY OTHER PURPOSES BEYOND THE SPECIFIC PURPOSE FOR WHICH THIS DOCUMENT WAS DELIVERED WITHOUT THE EXPRESS WRITTEN PERMISSION OF CAPSTONE TURBINE CORPORATION.  
2002 CAPSTONE TURBINE CORPORATION - ALL RIGHTS RESERVED

| REVISIONS |             |      |          |
|-----------|-------------|------|----------|
| LTR       | DESCRIPTION | DATE | APPROVED |
| -         | -           | -    | -        |

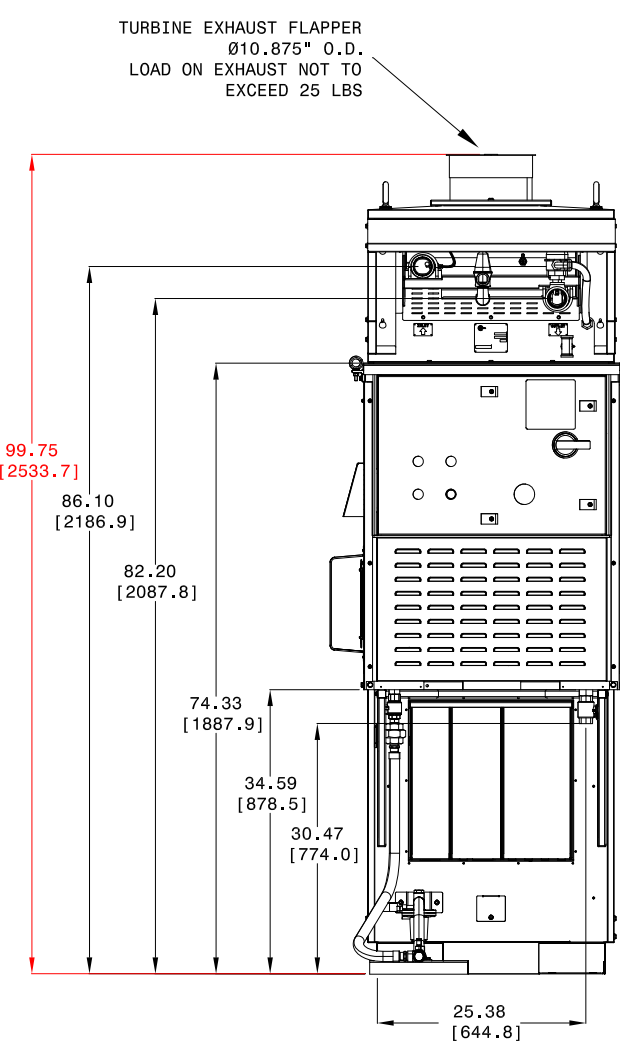
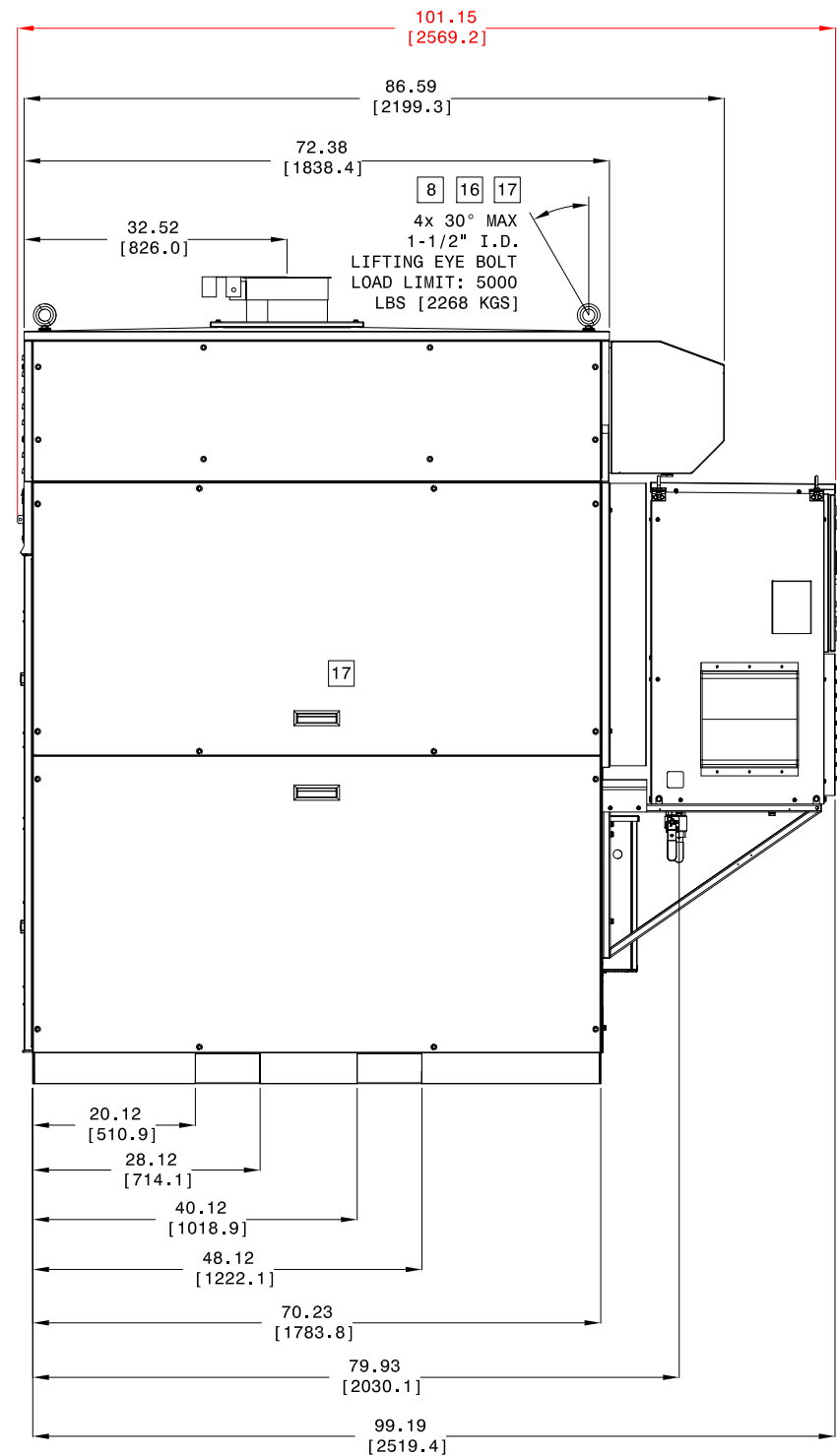
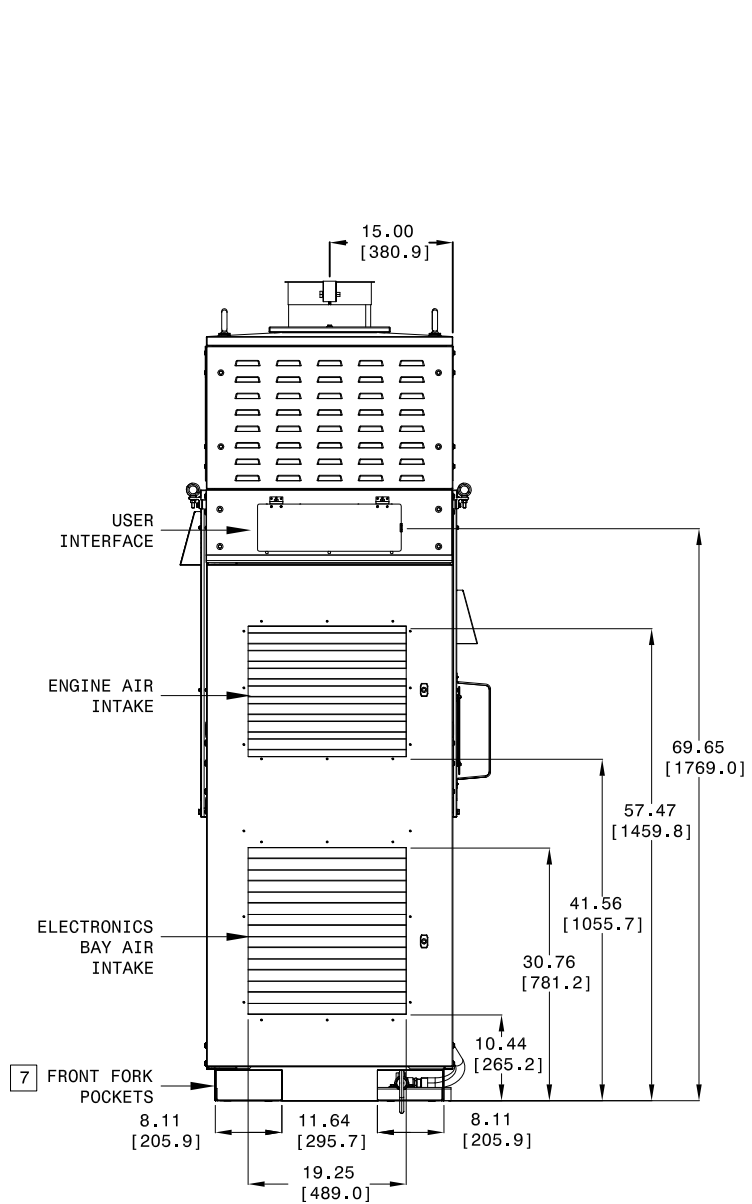

SEE NOTE 13

COPY IS UNCONTROLLED; USER IS RESPONSIBLE TO VERIFY CURRENT REVISION

|          |              |     |   |
|----------|--------------|-----|---|
| DWG NO.  | 529765       | REV | A |
| VERSION: | SHEET 2 OF 4 |     |   |

**NOTICE**

THIS DOCUMENT CONTAINS INFORMATION WHICH IS BOTH CONFIDENTIAL AND PROPRIETARY TO CAPSTONE TURBINE CORPORATION. NEITHER THIS DOCUMENT NOR THE INFORMATION CONTAINED HEREIN SHALL BE COPIED, DISCLOSED TO OTHERS OR USED FOR ANY OTHER PURPOSES BEYOND THE SPECIFIC PURPOSE FOR WHICH THIS DOCUMENT WAS DELIVERED WITHOUT THE EXPRESS WRITTEN PERMISSION OF CAPSTONE TURBINE CORPORATION.  
2002 CAPSTONE TURBINE CORPORATION - ALL RIGHTS RESERVED

| REVISIONS |             |      |          |
|-----------|-------------|------|----------|
| LTR       | DESCRIPTION | DATE | APPROVED |
| -         | -           | -    | -        |

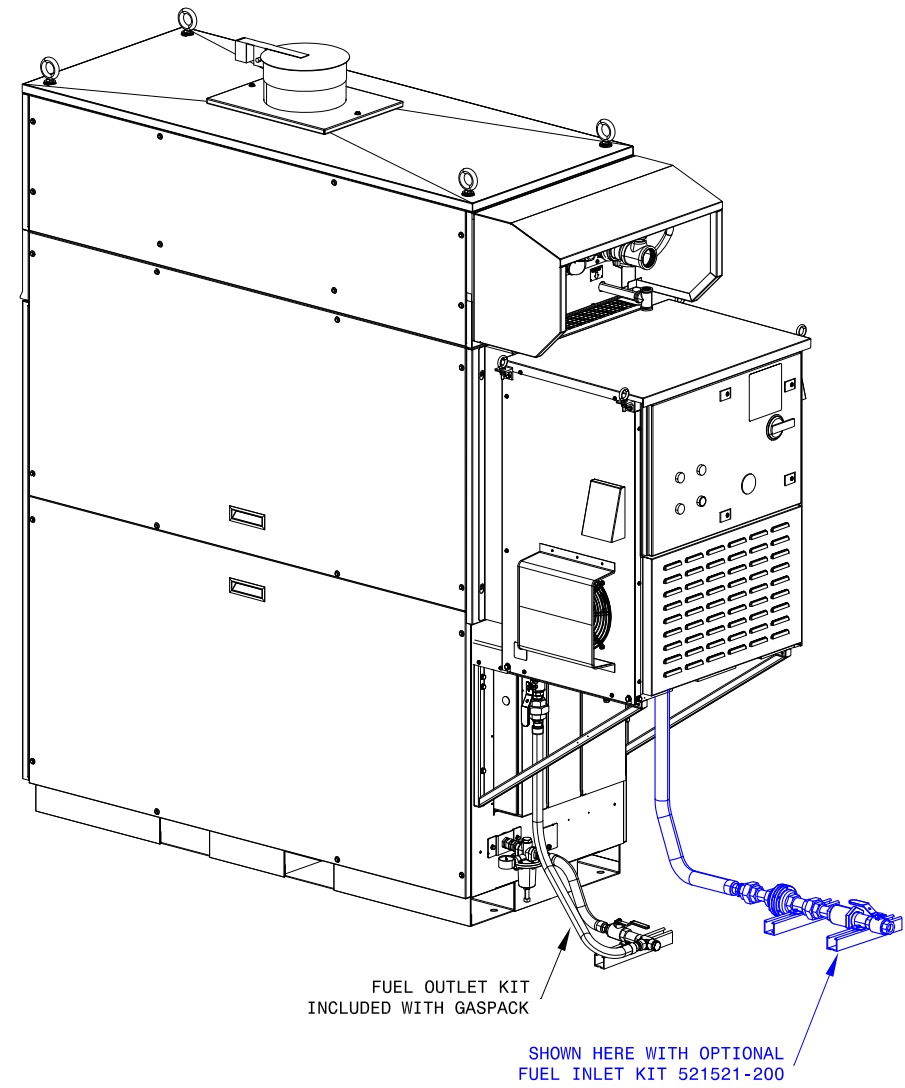
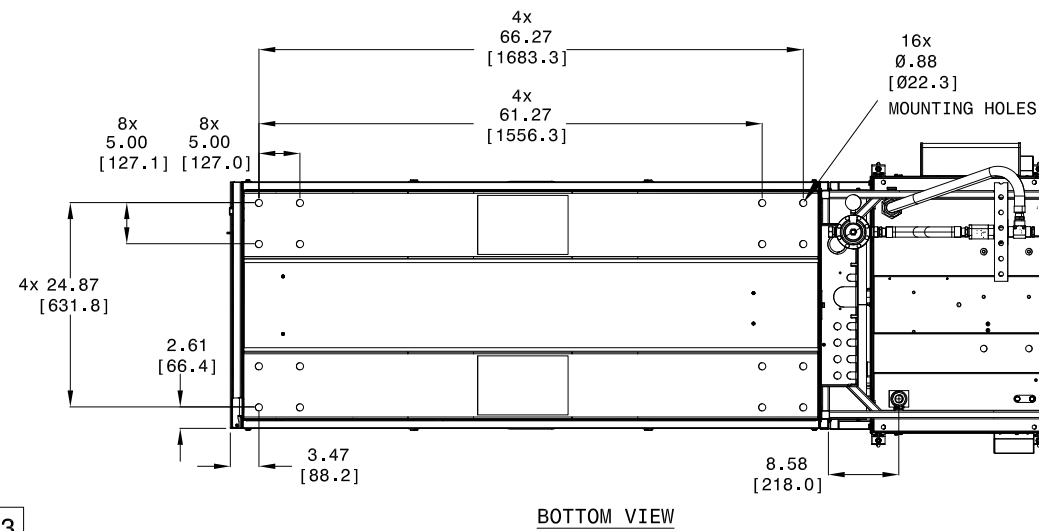
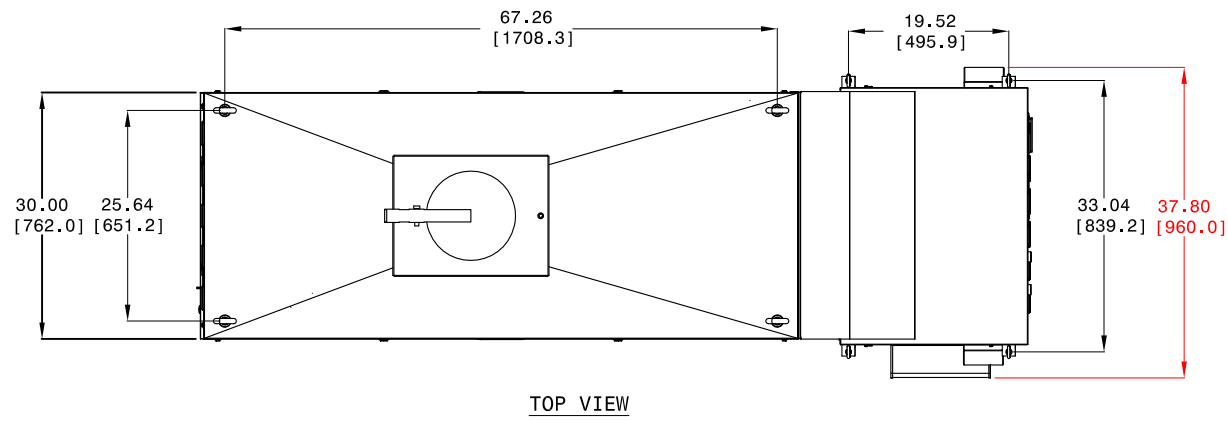
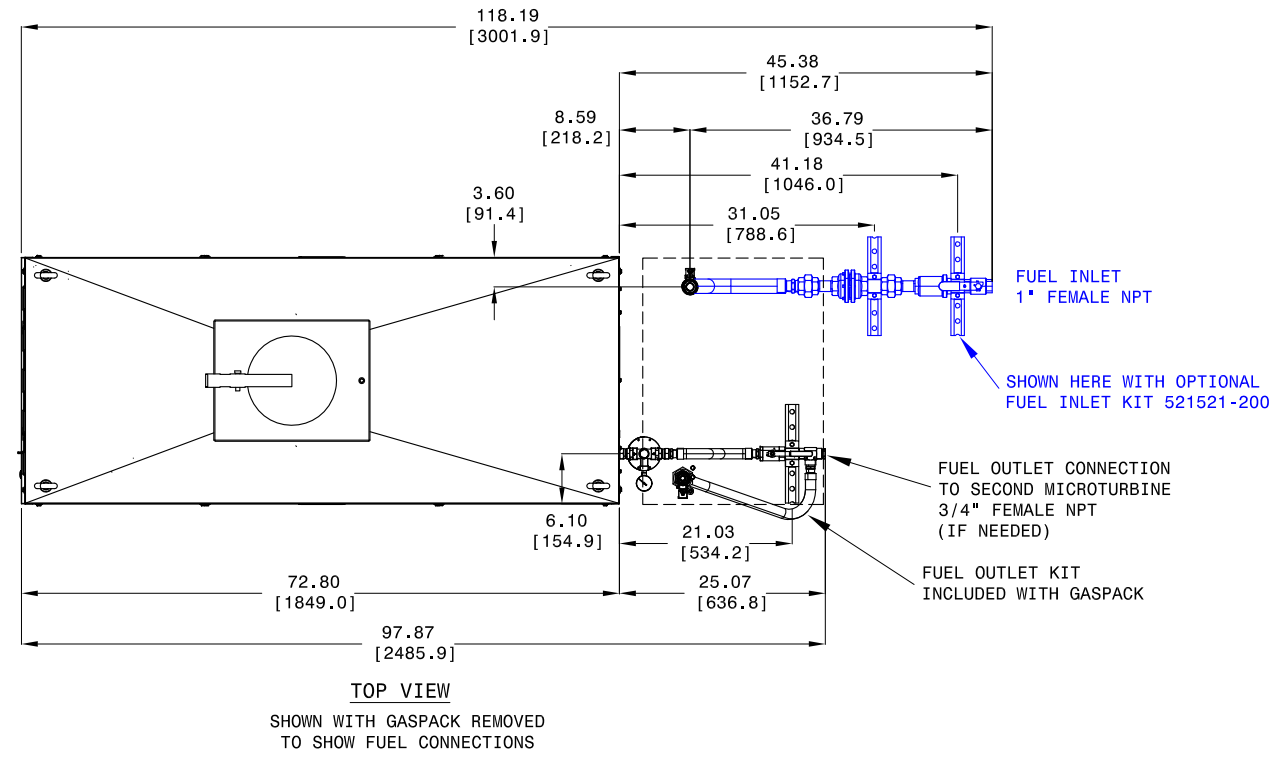

SEE NOTE 13

COPY IS UNCONTROLLED; USER IS RESPONSIBLE TO VERIFY CURRENT REVISION

|          |              |     |   |
|----------|--------------|-----|---|
| DWG NO.  | 529765       | REV | A |
| VERSION: | SHEET 3 OF 4 |     |   |

REVISIONS

| LTR | DESCRIPTION | DATE | APPROVED |
|-----|-------------|------|----------|
| -   | -           | -    | -        |

NOTICE

THIS DOCUMENT CONTAINS INFORMATION WHICH IS BOTH CONFIDENTIAL AND PROPRIETARY TO CAPSTONE TURBINE CORPORATION. NEITHER THIS DOCUMENT NOR THE INFORMATION CONTAINED HEREIN SHALL BE COPIED, DISCLOSED TO OTHERS OR USED FOR ANY OTHER PURPOSES BEYOND THE SPECIFIC PURPOSE FOR WHICH THIS DOCUMENT WAS DELIVERED WITHOUT THE EXPRESS WRITTEN PERMISSION OF CAPSTONE TURBINE CORPORATION.  
2002 CAPSTONE TURBINE CORPORATION - ALL RIGHTS RESERVED

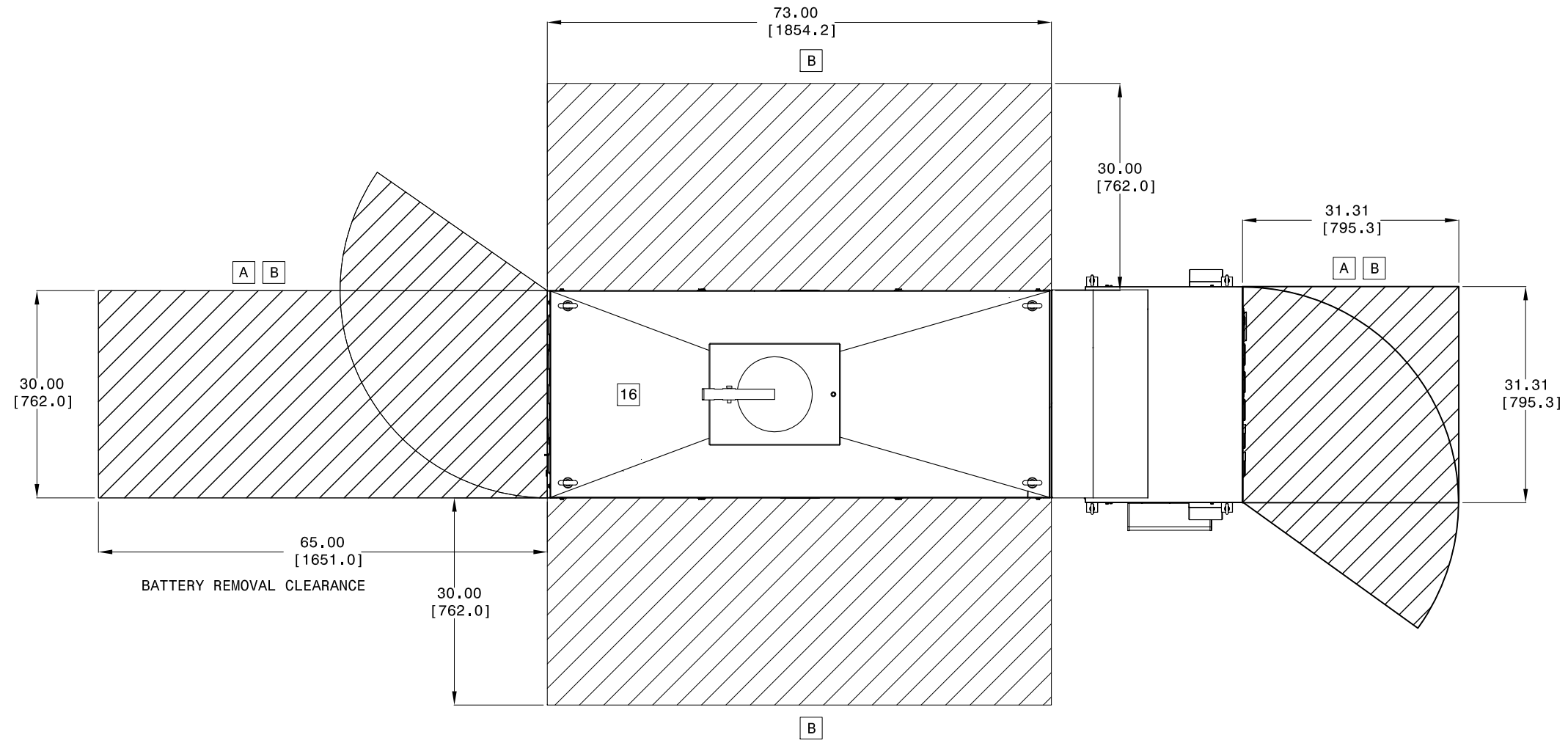

SERVICE CLEARANCES [3]

- [A] REQUIRED FOR ROUTINE MAINTENANCE
- [B] REQUIRED FOR OVERHAUL MAINTENANCE AND TROUBLESHOOTING

SEE NOTE [13]

COPY IS UNCONTROLLED; USER IS RESPONSIBLE TO VERIFY CURRENT REVISION

|          |              |     |   |
|----------|--------------|-----|---|
| DWG NO.  | 529765       | REV | A |
| VERSION: | SHEET 4 OF 4 |     |   |