

NOTICE
 THIS DOCUMENT CONTAINS INFORMATION WHICH IS BOTH CONFIDENTIAL AND PROPRIETARY TO CAPSTONE TURBINE CORPORATION. NEITHER THIS DOCUMENT NOR THE INFORMATION CONTAINED HEREIN SHALL BE COPIED, DISCLOSED TO OTHERS OR USED FOR ANY OTHER PURPOSES BEYOND THE SPECIFIC PURPOSE FOR WHICH THIS DOCUMENT WAS DELIVERED WITHOUT THE EXPRESS WRITTEN PERMISSION OF CAPSTONE TURBINE CORPORATION.
 2002 CAPSTONE TURBINE CORPORATION - ALL RIGHTS RESERVED

- UNLESS OTHERWISE SPECIFIED
- 1 INTERPRET DRAWING PER ANSI Y14.5M-1982.
 - 2 ALL DIMENSIONS ARE IN INCHES.
 - 3 FRONT, SIDE AND REAR CLEARANCES SHOULD BE PROVIDED FOR SERVICE ACCESS. LOCAL ELECTRICAL CODES SHALL PRESCRIBE MINIMAL REAR CLEARANCE FOR ACCESS TO JUNCTION BOX.
 - 4 MOUNT LEVEL WITHIN 2% GRADE. SURFACE MUST DRAIN TO PREVENT STANDING WATER.
 - 5 REFER TO PRODUCT CATALOG FOR OPTIONAL ACCESSORIES.
 - 6 REFER TO CAPSTONE MICROTURBINE FUEL TECHNICAL REFERENCE MANUAL 410002.
 - 7 LIFT UNIT WITH FIVE INCH WIDE FORK LIFT BLADES.
 - 8 FOR OVERHEAD LIFTING OF UNIT; STRAPS SHALL NOT EXCEED 30° FROM VERTICAL.
 - 9 THIS APPLIES TO DUAL MODE OR STAND ALONE SYSTEMS.
 - 10 THIS APPLIES TO GRID CONNECT SYSTEMS.
 - 11 ADDITIONAL PRODUCT SPECIFICATION INFORMATION IS CONTAINED IN THE PRODUCT SPECIFICATION 460000.
 - 12 ADDITIONAL ELECTRICAL INFORMATION IS CONTAINED IN THE C30 ELECTRICAL TECHNICAL REFERENCE 410000.
 - 13 ADDITIONAL PERFORMANCE INFORMATION IS CONTAINED IN THE PERFORMANCE TECHNICAL REFERENCE 410004.
 - 14 HAND TIGHTEN LIFTING EYE AND TIGHTEN ADDITIONAL 3/4 TO 1 TURN TO SECURE LIFTING PARALLEL WITH LONG SIDE OF UNIT.
 - 15 ROOF IS A "NO STEP" ZONE.

8
7
6
5
4
3
2
1

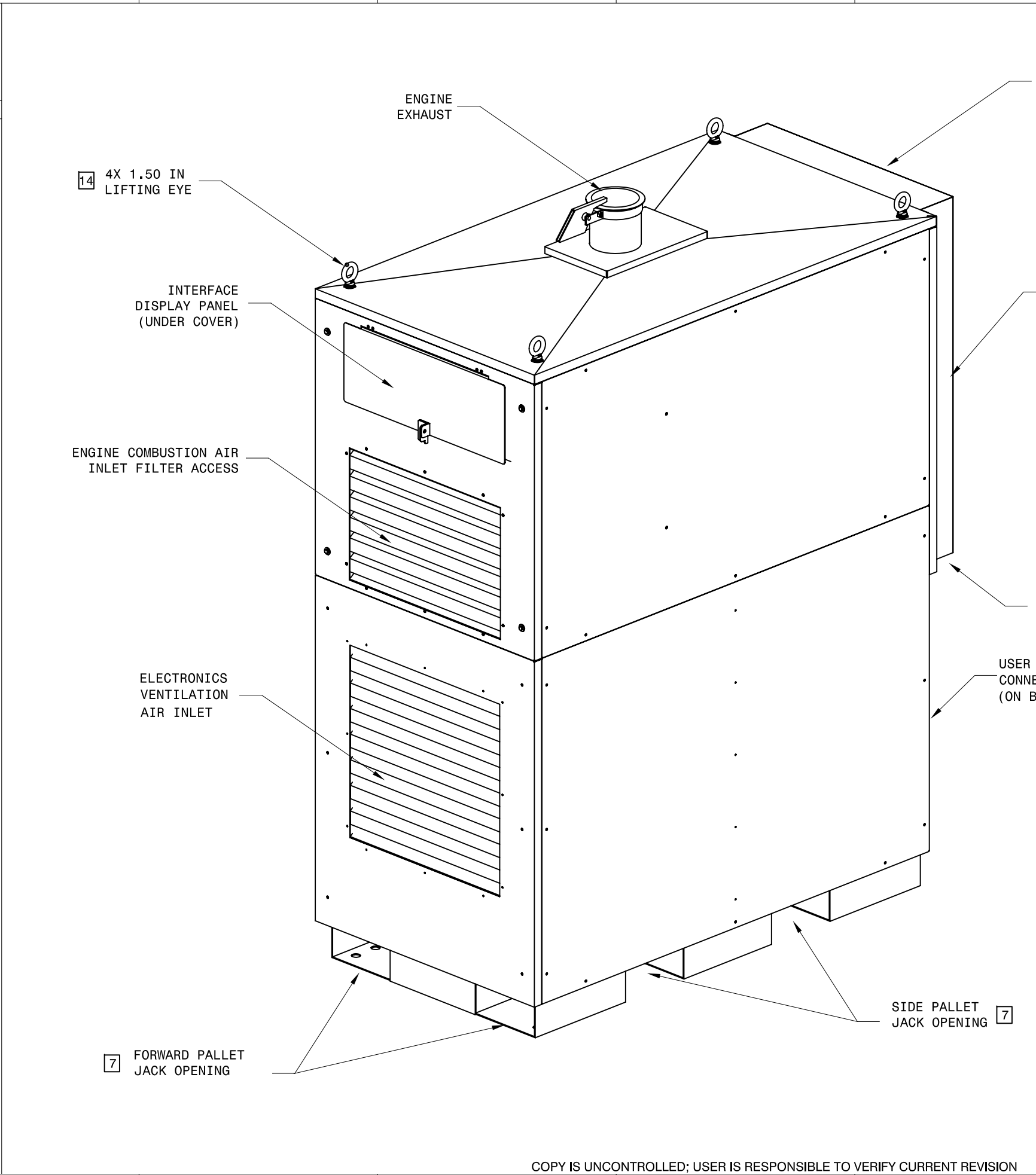

REVISIONS			
LTR	DESCRIPTION	DATE	APPROVED
A	PRODUCTION RELEASE	5/25/07	D. RESH
B	O&I STANDARDIZATION	06/09/11	P. BREAUULT



WEIGHTS		
DUAL MODE	1271 LBS	578 KG
GRID CONNECT	891 LBS	405 KG

LUGS SIZES/ELECTRICAL CONNECTIONS		
	WIRE SIZE	TORQUE
HIGH POWER	2/0 TO #6 AWG	120 IN LBS
	62 TO 13 mm ²	1.38 KG-M
NEUTRAL TO GROUND		30 IN LBS
		0.34 KG-M

FUELS	FUEL INLET	MODES	
		DM	GC
LPNG	37° FLARE AN-12 (ADAPTER 3/4" FEMALE NPT-LOOSE SHIPPED)	X	X
HPNG	37° FLARE AN-12 (ADAPTER 3/4" FEMALE NPT-LOOSE SHIPPED)	X	X
LIQUID	37° FLARE AN-6*	X	X
PROPANE	37° FLARE AN-12 (ADAPTER 3/4" FEMALE NPT-LOOSE SHIPPED)	X	X
LANDFILL (TYPE A)	37° FLARE AN-12 (ADAPTER 3/4" FEMALE NPT-LOOSE SHIPPED)		X
DIGESTER (TYPE B)	37° FLARE AN-12 (ADAPTER 3/4" FEMALE NPT-LOOSE SHIPPED)		X
HPSG	37° FLARE AN-12 (ADAPTER 3/4" FEMALE NPT-LOOSE SHIPPED)		X

*SEE NEXT PAGE FOR DRAIN SIZE

UNLESS OTHERWISE SPECIFIED DIMENSIONS ARE IN INCHES TOLERANCES ARE:		APPROVALS		Capstone Turbine Corporation 21211 NORTHOFF STREET CHATTANOOGA, GA 31211	
FRACTIONS ±1/32	DECIMALS .XX ±.000	ANGLES ±.2°	DFTG: P. BREAUULT	05/20/11	TITLE O&I, C30, IND PKG
			CHRR: R. MOHIDEEN	06/05/11	
			ENG MGR: G. TERZER	05/20/11	
MATERIAL:			MATL: -		
COMPL: -			COMPL: -		
FINISH:			PERF: -		
			MFG: -		
DO NOT SCALE DRAWING	COG ENG: P. BREAUULT	06/09/11	SCALE:		
			SIZE: D	FSCM NO.:	DWG NO. 518834
					REV B
					DR: 10022607 SHEET 1 OF 3

COPY IS UNCONTROLLED; USER IS RESPONSIBLE TO VERIFY CURRENT REVISION

NOTICE

THIS DOCUMENT CONTAINS INFORMATION WHICH IS BOTH CONFIDENTIAL AND PROPRIETARY TO CAPSTONE TURBINE CORPORATION. NEITHER THIS DOCUMENT NOR THE INFORMATION CONTAINED HEREIN SHALL BE COPIED, DISCLOSED TO OTHERS OR USED FOR ANY OTHER PURPOSES BEYOND THE SPECIFIC PURPOSE FOR WHICH THIS DOCUMENT WAS DELIVERED WITHOUT THE EXPRESS WRITTEN PERMISSION OF CAPSTONE TURBINE CORPORATION.
2002 CAPSTONE TURBINE CORPORATION - ALL RIGHTS RESERVED

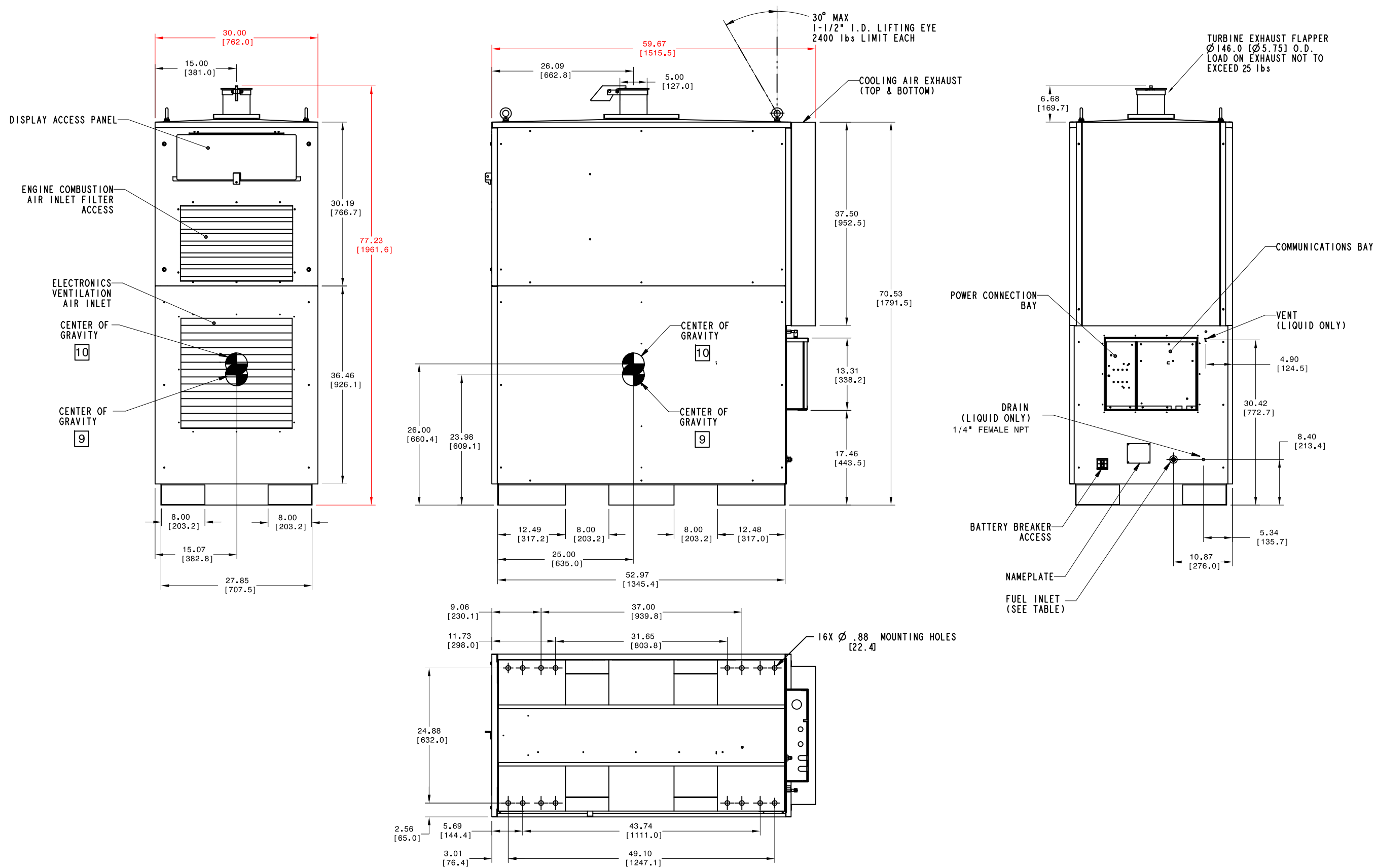

COPY IS UNCONTROLLED; USER IS RESPONSIBLE TO VERIFY CURRENT REVISION

DWG NO.	518834	REV	B
SHEET 2 OF 3			

DFTG	DATE	CHGR	DATE	ENG MGR	DATE	MATL	DATE	COMPL	DATE	PERF	DATE	MFG ENG	DATE	COG ENG	DATE
------	------	------	------	---------	------	------	------	-------	------	------	------	---------	------	---------	------

8

7

6

5

4

3

2

1

NOTICE

THIS DOCUMENT CONTAINS INFORMATION WHICH IS BOTH CONFIDENTIAL AND PROPRIETARY TO CAPSTONE TURBINE CORPORATION. NEITHER THIS DOCUMENT NOR THE INFORMATION CONTAINED HEREIN SHALL BE COPIED, DISCLOSED TO OTHERS OR USED FOR ANY OTHER PURPOSES BEYOND THE SPECIFIC PURPOSE FOR WHICH THIS DOCUMENT WAS DELIVERED WITHOUT THE EXPRESS WRITTEN PERMISSION OF CAPSTONE TURBINE CORPORATION.
2002 CAPSTONE TURBINE CORPORATION - ALL RIGHTS RESERVED

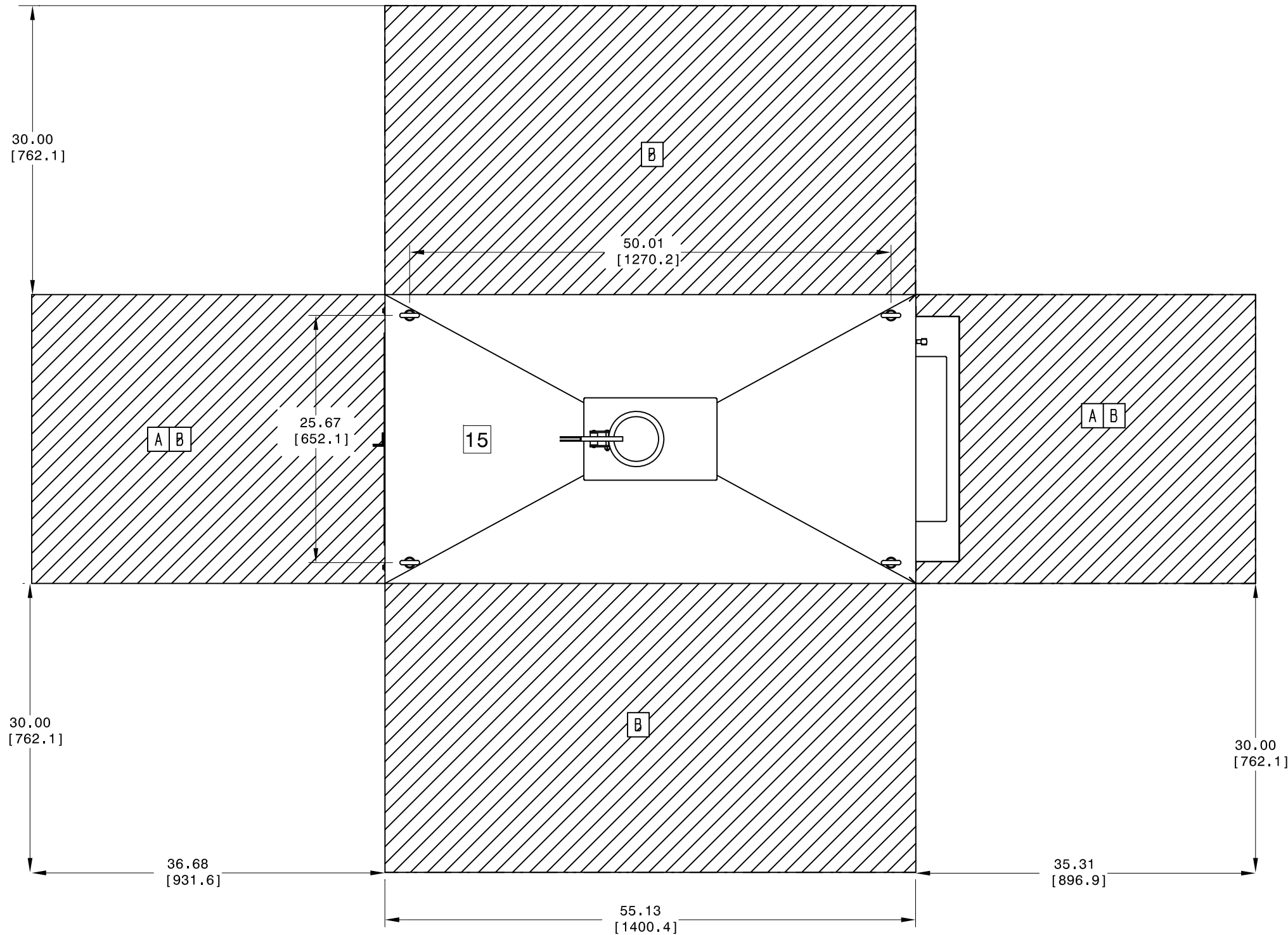

SERVICE CLEARANCES 15

- A REQUIRED FOR ROUTINE MAINTENANCE
- B REQUIRED FOR OVERHAUL MAINTENANCE

COPY IS UNCONTROLLED; USER IS RESPONSIBLE TO VERIFY CURRENT REVISION

DWG NO.	518834	REV	B
SHEET 3 OF 3			

8

7

6

5

4

3

2

1